

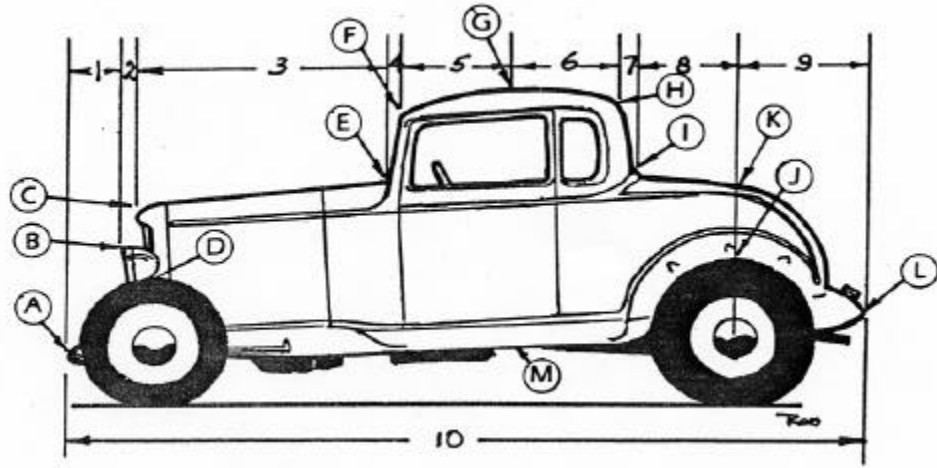

1932 Ford
Coupe
no bumpers
or fenders



- Lengths - Measured Horizontally**
- # 1 Front of car to front of headlight _____
 - # 2 Front of headlight to front of hood _____
 - # 3 Front of hood to base of windshield _____
 - # 4 Base of windshield to front of roof _____
 - # 5 Front of roof to highpoint of roof _____
 - # 6 Highpoint of roof to rear of roof _____
 - # 7 Rear of roof to base of rear window _____
 - # 8 Base of window to center of rear axle _____
 - # 9 Center of rear axle to rear of car _____
 - # 10 Overall length of car, front to rear _____

If you have measured correctly, the sum of # 1 through # 9 should equal # 10.

- Heights - Measured from Ground**
- HA Height at front of car _____
 - HB Height at top of headlight _____
 - HC Height at front of hood _____
 - HD Height at top of front tire _____
 - HE Height at base of windshield _____
 - HF Height at front of roof _____
 - HG Height at highpoint of roof _____
 - HH Height at rear of roof _____
 - HI Height at base of rear window _____
 - HJ Height of rear tire _____
 - HK Height of trunk at point "K" _____
 - HL Height at rear of car _____
 - HM Road clearance _____

Widths, Measured Side to Side at Points Shown

- WA Width of car at front _____
- WB Width of car at top of headlights _____
- WC Width of hood at front _____
- WD Width of car at front tires _____
- WE Width of car at base of windshield _____
- WF Width of roof at front _____
- WG Width of roof at highpoint _____
- WH Width of roof at rear _____
- WI Width at base of rear window _____
- WJ Width of car at rear tires _____
- WK Width of car across trunk at "K" _____
- WL Width of car at rear _____

Vehicle Information

A photo of the vehicle will help us make the pattern. The photo can be returned if requested.

YEAR _____ MAKE _____

MODEL _____ BODY STYLE _____

Name _____

Daytime phone _____

Date of order _____